

Radius^{HD}

Owners Manual

Contents Page

Important Safety Instructions _____	2
Safety Instructions For Fixing Your Radius ^{HD} Loudspeakers to a Wall _____	3
Re-cycling _____	3
RoHS Declaration of Conformity _____	3
Background _____	3
Introduction _____	4
Setting up and Positioning _____	5
Positioning - Front Speakers _____	5
Positioning - Surround Speakers _____	5
Optimum Speaker Placement _____	6
Fixing to the Wall _____	7
Fixing the R45 ^{HD} / R90 ^{HD} to a Wall _____	8
Fixing the R180 ^{HD} / R225 ^{HD} / R250 ^{HD} / R one ^{HD} to a Wall _____	9
R270 ^{HD} Feet and Spikes _____	10
Specifications _____	11
Guarantee and Service _____	12
Claims under this Guarantee _____	12
Data Protection _____	13
Owner Information _____	13
EC Declaration of Conformity _____	14

Important Safety Instructions

1. **Please read these instructions.**
2. **Please keep these instructions.**
3. **Heed all warnings.**
4. **Follow all instructions.**
5. **Do not use this apparatus with water.**
6. **Clean only with a dry cloth.** Great care and attention has gone into the materials chosen to produce the Radius HD Series. A gentle wipe with a dry, clean cloth is all that is required to remove any dust. Treat them as you would a fine piece of furniture because that is how they have been designed.
7. **Do not install near any heat source**, such as radiators, heat registers, stoves, or other apparatus (including amplifiers) that produce heat.
8. **Only use attachments/ accessories specified by Monitor Audio.**
9. **Use only with the cart**, stand, tripod, bracket, or table specified by monitor Audio or sold with the apparatus. When a cart is used, use caution when moving the cart/ apparatus combination to avoid injury from tip-over.



10. **Refer all servicing to qualified service personnel.** Servicing is required when the apparatus has been damaged in any way, such as power supply cord or plug is damaged, liquid has been spilled or objects have fallen onto the apparatus, the apparatus has been exposed to rain or moisture, does not operate normally or has been dropped.
11. **This apparatus shall not be exposed to dripping or splashing water** and that no object filled with liquids such as vases shall be placed on the apparatus.
12. **This exclamation point within an equilateral triangle** is intended to alert the user to the presence of important maintenance (servicing) instructions in the literature accompanying the appliance.



Safety Instructions For Fixing Your Radius^{HD} Loudspeakers to a Wall



WARNING: For safety reasons do not attempt to fix these speakers to your wall if you are unsure of your ability to provide a secure and safe fixing. You will need to determine where to fit the bracket and the structure of the wall. If unsure, please obtain the services of a competent qualified trades-person.



WARNING: Ensure that there are no water pipes, or electricity cables running behind where the wall bracket is going to be secured. Work from secure steps and avoid trailing wires.

Re-cycling

Correct Disposal of Waste Electrical and Electronic Equipment (WEEE) by User in Private Households in the EU.

This symbol on the product or accessories indicates that they must not be disposed of with your household wastes throughout the EU. To prevent possible harm to the environment or human health from uncontrolled waste disposal, recycle it responsibly to promote the sustainable reuse of material resources. Instead it is your responsibility to dispose of your waste equipment by handing it over to a designated WEEE collection point for recycling. The separate collection and recycling of your waste equipment will help conserve natural resources and ensure that it is recycled in a manner that protects human health and the environment.



For more specific information about where you can take your equipment for recycling please contact your local city/council office, your local waste disposal service or the outlet where you purchased your Radius^{HD} product.

RoHS Declaration of Conformity

Directive 2002/95/EC of the European Parliament and of the Council on the reduction of the use of certain hazardous substances in electrical and electronic equipment, January 2003.



Background

The RoHS directive restricts the use of Lead (Pb), Cadmium (Cd), Mercury (Hg), hexavalent Chromium (CrVI), polybrominated biphenyl (PBB) compounds, and polybrominated diphenyl ether (PBDE) compounds in electrical and electronic equipment sold in the European Union.

Introduction

Congratulations and thank you for your purchase of the Radius^{HD} loudspeakers. We are confident they will provide years of enjoyment and pleasure as only high quality components have been used throughout.

Building on the overwhelming success of the original Radius Series, Radius^{HD} brings redesigned cabinet profiles, enhanced cabinet structure, improved aesthetics and improved sonic balance and response.

The R270^{HD} has received major performance enhancements in every area. We have increased the cabinet volume, added an additional rear firing port and also added ballast in the bottom of the cabinet. All of these new features combined to offer improved, tighter, punchier bass response and extra cabinet stability.

The R45^{HD} and R90^{HD} come supplied with a wall fixing bracket. This enable upto 18 degrees of movement in all directions.

We have also introduced a new product to the Radius^{HD} Series, the R one^{HD}. The R one^{HD} is a left, centre, right in one cabinet. Each channel is enhanced with it's own braced compartment and individually specified crossovers. Designed to fit below/ above your TV where the centre channel would normally sit, additional left and right speakers are not needed as the R one^{HD} houses all three in one.

Please follow this user manual carefully as it contains important information about positioning and set up procedures. For further advanced information on system set-up, FAQ's and multi-lingual support please refer to our web site at: www.monitoraudio.co.uk



The R45^{HD} has a thermal protection device in it. This helps to protect the drive unit and tweeter from permanent damage. If the speaker stops working after a long period of play, turn off the source for about 10 minutes, and retry.



Setting up and Positioning

Although position and suitability will have been considered prior to purchasing your Radius^{HD}, this section will guide you through the optimum positioning and setting up of your loudspeakers. An illustration is provided on page 6 to assist you in ensuring your speakers are placed in the optimum positions. For instructions on fitting your Radius^{HD} speakers to a wall, please go to pages 7,8 & 9. Self adhesive rubber feet are provided to prevent movement due to vibration when using the Radius^{HD} on a table/ equipment stand. The R270^{HD} comes supplied with rubber feet fitted into the plinth. Further details on these can be found on page 10.

R one^{HD}

This cabinet simply needs to be placed either just below or just above your TV/ projector screen. Ideally, it should be angled towards your listening position.

Positioning - Front Speakers

With the centre channel the tweeter is best pointed towards the listener's ears to help direct the sound and should be the first speaker you place in your home theatre room. The centre channel's job is to anchor dialogue and other on-screen sounds to the screen. Typically, As much as 60% of a movie soundtrack comes through the centre channel .

The centre channel can be placed either above or below your TV screen, and as close as possible. If positioned in a cabinet or sitting on top of the TV ensure that the front edge is aligned with the front edge of the TV or shelf. Where possible, the height of the centre channel's tweeter should be close to the height of your front speakers' tweeter — ideally, within about 600mm.

When placing your Radius^{HD} loudspeakers on the wall, around a plasma/ LCD TV, the left and right speakers need to be between 22 & 30° to the left and right of the seating position, with the tweeters at approximate ear level.

Positioning - Surround Speakers

Ideally, your primary pair of surround speakers should be placed to the left and right of your listening position — either in line with it, or just behind it (90 - 110°). If you have a 6.1 channel or 7.1 channel system with more than two surround speakers, or if side placement isn't available in a 5.1 channel system, consider placement behind your listening position, facing the front of the room (135 - 150°).

Surround speakers should be placed high enough so that the drivers do not fire directly at your ears when you're sitting down — one rule of thumb is to place them at ear level while standing. If your surround speakers fire directly at your ears, they can overpower your front speakers.

If your surrounds are mounted on the side walls on brackets (R45^{HD} & R90^{HD}), experiment with aiming them. You may get good results from pointing them at the ceiling or toward the rear corners of the room.

Surround speaker placement which is ideal for home theatre may not necessarily be perfect for multichannel music listening, where a precisely focused rear soundstage is best. If both types of listening are important to you, then you can position your surround speakers for a compromise between the two.

Optimum Speaker Placement

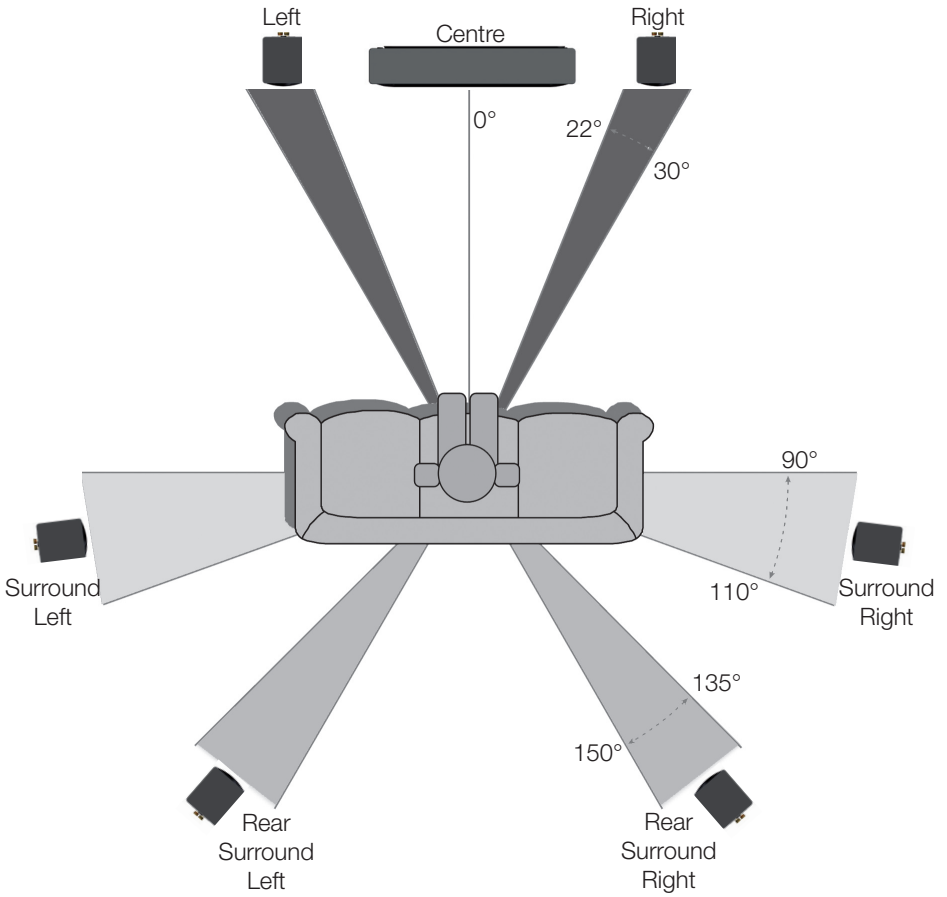

Figure 1.

Fixing to the Wall

The R45^{HD} & R90^{HD} come with a bracket to mount it on the wall. It is fixed using the 2 button head screws on the back of the cabinet either side of the terminals.



WARNING: Ensure that there are no water pipes, or electricity cables running behind where the wall bracket is going to be secured. Work from secure steps and avoid trailing wires.

WARNING: Do not connect your speaker cable to the amplifier before connecting it to the speaker.

When you unpack the Radius Wall Bracket you will notice that it is packed in two parts. Please do not put these two pieces together before fixing to the wall.

1. Remove the backing from the 'low tack' adhesive on the back of the template. Offer the bracket template up to the wall, so that the fixing holes run vertically, ensuring that it is true. If you are happy, press it against the wall to hold it in place. Mark the centres of the two wall fixing holes with a bradawl, piercing through the template (examples can be seen in Fig.2 and Fig. 3). If your loudspeaker cable has been/going to be run through the wall remember to take this into consideration when fixing the bracket to the wall. Please see the template for reference dimensions.

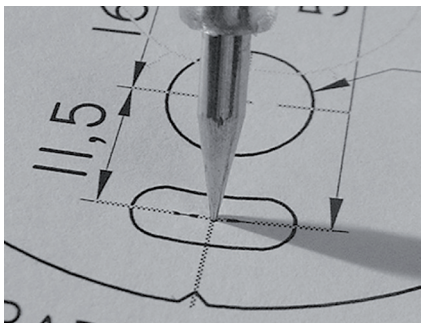

Figure 2.

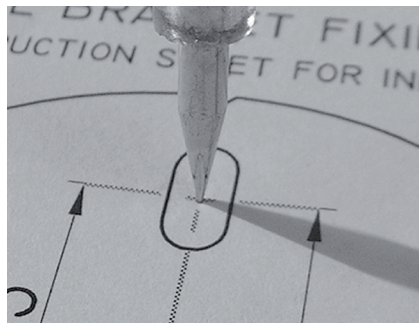

Figure 3.

2. For fixing to plasterboard (sheet-rock) or a solid wall use a suitable 6.5mm (1/4") drill bit. Drill the two positions deep enough to accept the wall plugs provided, this should be 30mm (1 1/8"). Insert the wall plugs into the wall. If your cable has been run through the wall, feed it through the hole in your wall bracket and then screw the bracket to the wall using the 25mm (1") screws provided. There are two small markers on the wall bracket to ensure vertical/horizontal alignment.

3. For fixing to a wooden wall/structure, use a 2mm drill bit to drill 2 pilot holes and use 25mm screws to secure the bracket.
4. Fully unscrew the 2 wall bracket mounting screws in the back of the speaker cabinet using the 'hex' key provide (Fig. 4). Using the two screws that have just been removed, attach the forked part of the wall bracket to the back of the speaker (Fig. 5). This should be tightened securely.



Figure 4.



Figure 5.

5. Connect the speaker cables as in Fig. 6. Alternatively, you can use bare wire. Place the female ball part of the bracket over the male part, ensuring the slot in the female part lines up with the hole in the male part.
6. Using the 30mm cap head bolt (provided) secure the two parts together, but leave the bolt loose enough to allow some adjustment if necessary (Fig. 7).
7. Adjust the speaker to the desired listening position and fully tighten the bolt. If you realise this is not the correct positioning, loosen the bolt slightly, re-adjust and then tighten the bolt.

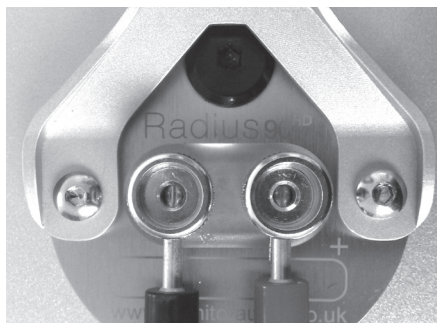

Figure 6.

Connect your speaker cable to the amplifier

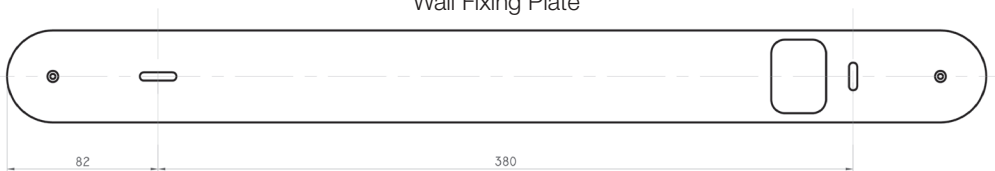
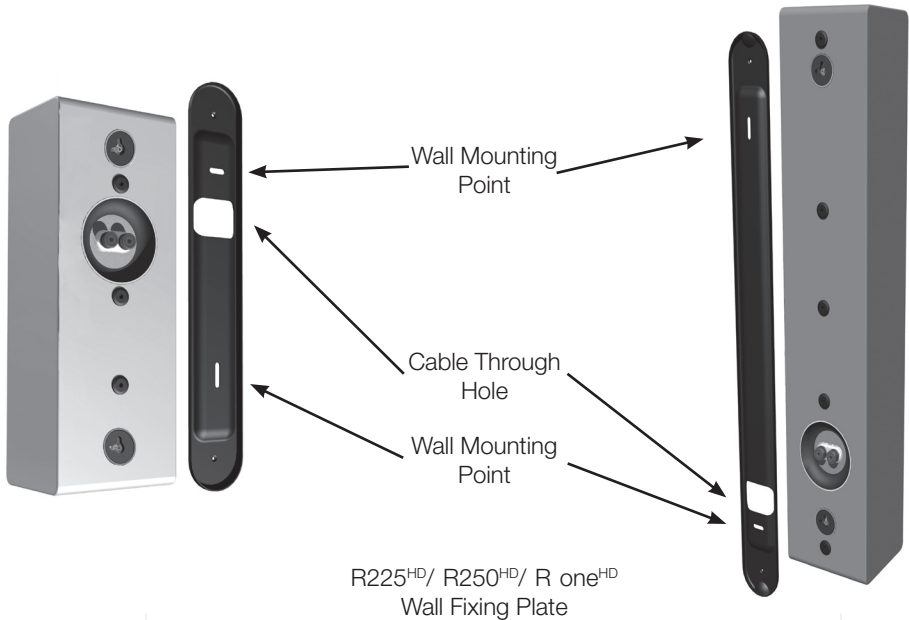

Figure 7.

Fixing the R180^{HD}/ R225^{HD}/ R250^{HD}/ R one^{HD} to a Wall

Additional Points to Remember

- When using the wall fixing plate, the speaker will drop by 7.5mm due to the key hole fixing.
- Templates are supplied with the products to aid fixing.
- The grille badge can be rotated. Simply apply some pressure with your thumb/ finger and rotate it.
- Please allow no more than 200mm (8 inches) of slack cable protruding from the wall. All unused cable can be wound around the inside of the terminal panel.
- Please see the template for information on the locations of the rubber feet.



R180^{HD} Wall Fixing Plate



R270^{HD} Feet and Spikes

Your R270^{HD} will come with rubber feet inserted into the plinth inserts (pictured below). This is for use on hard floors or when spikes are inappropriate to use.



If you wish to use spikes, you can remove the rubber feet by simultaneously twisting and pulling them.



The threaded inserts in the plinth will be revealed when the rubber feet are removed. Take the spikes and twist them in a clockwise direction into the plinths. Ensure they are fully inserted and stand the cabinet up and place it in its final location to see if it is stable and level. If it is not adjust the spikes accordingly and then tighten the knurled locking nut to hold the spikes in that position.

Model	Radius 45 ^{HD}	Radius 90 ^{HD}	Radius 180 ^{HD}	Radius 225 ^{HD}	Radius 250 ^{HD}	Radius 270 ^{HD}	R one ^{HD}
Frequency Response	120Hz – 20 KHz	80Hz – 35 KHz	60 Hz – 35 KHz	55Hz – 35KHz	50Hz – 35KHz	48Hz - 35KHz	C: 55Hz – 35KHz L/R: 85Hz – 35KHz
Sensitivity (1W@1M)	87dB	87dB	87dB	90dB	90dB	90dB	C: 90dB L/R: 87dB
Nominal Impedance	8 Ohms	8 Ohms	8 Ohms	8 Ohms	8 Ohms	8 Ohms	C: 8 Ohms L/R: 8 Ohms
Power Handling Single (R.M.S)	25W	60W	60W	100W	100W	100W	C: 100W L/R 60W
System Power Handling (RMS)	50W	100W	100W	150W	150W	150W	C: 150W L/R: 100W
Recommended Amp Requirements	5-50 W	10-100 W	10-100W	20-150W	20-150W	20 - 150W	C: 20-150W L/R: 10-100W
Maximum SPL (dBA)	101	105	105	108	108	108	108
Bass Alignment	Sealed Cabinet	Bass reflex –rear ported	Bass reflex – front ported	Bass reflex – front ported	Bass reflex – front ported	Bass Reflex - Front & Rear Ported	C: Bass reflex – front ported L/R: Bass reflex – ported to underside
Drive Unit Complement	1x 3" MMP2 cone mid-bass driver. 1 x 20mm C-CAM gold dome tweeter	1x 4" MMP2 cone bass/ mid driver. 1 x 25mm C-CAM gold dome tweeter	1x 4" MMP2 cone bass/ mid driver. 1 x 25mm C-CAM gold dome tweeter	2x 4" MMP2 cone bass/ mid driver. 1 x 25mm C-CAM gold dome tweeter	2x 4" MMP2 cone bass/ mid driver. 1 x 25mm C-CAM gold dome tweeter	2x 4" MMP2 cone bass/ mid driver. 1 x 25mm C-CAM gold dome tweeter	4x 4" MMP2 cone bass/ mid driver. 3 x 25mm C-CAM gold dome tweeter
External Dimensions. mm (H x W x D)	100 x 100 x 100	198 x 125 x 140	350 x 125 x 105	610 x 125 x 105	760 x 125 x 105	100 x 125 x 140 (Without spikes)	1010 x 125 x 105
External Dimensions. inch (H x W x D)	3 15/16 x 3 15/16 x 3 15/16	7 13/16 x 4 15/16 x 5 1/2	13 3/4 x 4 15/16 x 4 1/8	24 x 4 15/16 x 4 1/8	29 15/16 x 4 15/16 x 4 1/8	39 3/8 x 4 15/16 x 5 ½ (Without spikes)	39 3/4 x 4 15/16 x 4 1/8
Weight (each) Kg (lb)	0.95 (2 1/8)	2 (4 3/8)	2.8 (6 1/8)	4.8 (10 1/2)	5.2 (11 1/2)	10.2 (22 1/2)	8 (17 5/8)

Guarantee and Service

To validate your warranty please visit www.monitoraudio.co.uk within 30 days of purchase.

When you register here you'll gain free entry to our monthly prize draw! What's more you'll be the first to hear about the great things happening at Monitor Audio, including new products and events!

This equipment has been fully tested prior to dispatch from the factory. Both the craftsmanship and the performance of this product is guaranteed against manufacturing defects for the period of **three years** from the date of purchase (see conditions below), provided that the product was supplied by an authorised Monitor Audio retailer under the consumer sale agreement. (The words 'consumer sale' shall be construed in accordance with section 15 of the supply of goods act 1973). Monitor Audio accepts no responsibility for defects arising from accident, misuse, abuse, wear and tear, modification or operation outside of that specified within this instruction manual. Neither will responsibility be accepted for damage or loss occurring during transit to or from the parties claiming under this guarantee.

This guarantee covers both labour and parts. The liability of Monitor Audio is limited to the cost of repair or replacement of the defective parts (at the discretion of Monitor Audio) and under no circumstances extends to consequential losses or damage.

Claims under this Guarantee

The equipment should be returned in its original packaging to the original supplier where possible, or to any other authorised Monitor Audio dealer. If it is not possible to return the equipment by hand, then it should be sent carriage prepaid via a reputable carrier. If the original packing is not available replacement packaging can be purchased from Monitor Audio.

If you have any difficulties complying with these requirements please contact us at the following address:

Customer Service
Monitor Audio Ltd.
Unit 2, 24 Brook Road
Rayleigh
Essex
SS6 7XL
England

Tel: 44 (0) 1268 740580
Fax: 44 (0) 1268 740589
Internet: www.monitoraudio.co.uk
Email: info@monitoraudio.co.uk

This guarantee does not affect the statutory rights of the consumer under UK law.

Data Protection

We at Monitor Audio are committed to respecting the wishes and privacy of our customers. Any information you provide will be held in the strictest confidence and only used within the Monitor Audio organisation for the provision of services such as warranty claims or spare parts.

We may wish to contact you in the future to ensure you are happy with the products and standards of service we provide and to keep you up-to-date with the latest products and promotions we have to offer.

Should you wish not to be contacted by us either by post, e-mail or phone, please tick the box on the warranty form on the web site. Alternatively you can request not to be contacted in future by writing to Customer Service, at the address above.

Owner Information

Product Details

Model

Product Serial No

Date of Purchase

Dealer Details

Dealer Name

Address

.....

e-mail address

Monitor Audio reserves the right to alter specifications without notice.

EC Declaration of Conformity

We, Monitor Audio Ltd.
24 Brook Road
Rayleigh
Essex
SS6 7XL
England



Declare in own responsibility, that the Radius HD products described in this manual is in compliance with Technical Standards/Council Directives:

(LVD) 2006/95/EC Low Voltage Directive

EN60065: 2002+A1: 2006 Safety requirements for mains operated electronic and related apparatus for household and similar use.

(EMC) 89/336/EEC Electro Magnetic Compatibility

EN55013: 08.90+A12:08.94+A13:12.96 Limits and methods of measurement of radio disturbance characteristics of broadcast receivers and associated equipment.

EN55020: 12.94+A11:12.96 Electro magnetic immunity of broadcast receivers and associated equipment.

EN61000-3-2: 04.95+A1:1998+A2:1998 Electro magnetic compatibility (EMC) – Part 3: Limits – Section 2: Limits for harmonic current emissions (equipment input current up to and including 16 Ampere per phase).

EN6100-3-3: 01.95 Electro magnetic compatibility (EMC) – Part 3: Limits – Section 3: Limits of voltage fluctuations and flicker in low-voltage supply systems for equipment with rated current up and including 16 Ampere per phase.

Signed by: 

Name: D.S. Hartley

Position: Technical Director

Company: Monitor Audio Ltd



Monitor Audio Ltd.
Unit 2, 24 Brook Road
Rayleigh, Essex
SS6 7XL
England

Tel: 01268 740580

Fax: 01268 740589

Email: info@monitoraudio.co.uk

monitoraudio.co.uk

Designed in the United Kingdom

© 2008. Version 5